

Spannschrauben, Art. Nr. 17791...

mit besonders langem Spannweg entsprechend amerikanischer Norm FF-T-791, Typ 1, Form 1 mit 2 Gabeln, 2 Augen, 2 Haken, Gabel und Auge oder Haken und Auge, verzinkt & vergütet

Nenngröße Gewinde Ø x innere Länge d. Spannschloß- mutter in Zoll	Bruchlast in kg*				
	mit Haken und Auge	mit 2 Augen	mit 2 Haken	mit Gabel und Auge	mit 2 Gabeln
3/8 x 6	2.200	2.700	2.200	2.700	2.700
1/2 x 6	3.300	5.000	3.300	5.000	5.000
1/2 x 9	3.300	5.000	3.300	5.000	5.000
1/2 x 12	3.300	5.000	3.300	5.000	5.000
5/8 x 6	5.000	7.900	5.000	7.900	7.900
5/8 x 9	5.000	7.900	5.000	7.900	7.900
5/8 x 12	5.000	7.900	5.000	7.900	7.900
3/4 x 6	6.700	11.800	6.700	11.800	11.800
3/4 x 9	6.700	11.800	6.700	11.800	11.800
3/4 x 12	6.700	11.800	6.700	11.800	11.800
3/4 x 18	6.700	11.800	6.700	11.800	11.800
7/8 x 12	9.000	16.300	9.000	16.300	16.300
7/8 x 18	9.000	16.300	9.000	16.300	16.300
1 x 12	11.200	22.700	11.200	22.700	22.700
1 x 18	11.200	22.700	11.200	22.700	22.700
1 1/4 x 12	-	34.500	-	34.500	34.500
1 1/4 x 18	-	34.500	-	34.500	34.500
1 1/2 x 12	-	48.600	-	48.600	48.600
1 1/2 x 18	-	48.600	-	48.600	48.600

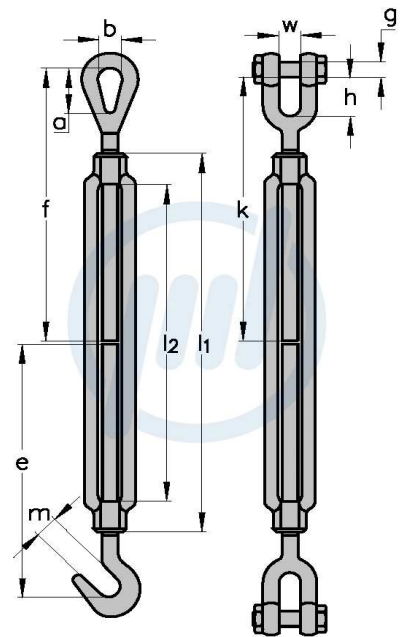



WIEDENMANN

... weil viel davon abhängt!

<p>90431 Nürnberg Egenhauser Str. 5 Tel +49 (0)911 6109530 Fax +49 (0)911 652032 info@ws-gruppe.de</p>	<p>97342 Marktsteft Am Traugraben 8 Tel. +49 (0)9332 50610 Fax +49 (0)9332 506118 www.ws-gruppe.de</p>	<p>06796 Sandersdorf OT Brehna/Delitzscher Str. 5 Tel. +49 (0)34954 90960 Fax +49 (0)34954 909619 shop.ws-gruppe.de</p>	<p>42859 Remscheid Rosenhügeler Str. 28 Tel. +49 (0)2191 6925460 Fax +49 (0)2191 6925461</p>
---	--	--	--